

THE INFORMATION CONTAINED IN THIS DOCUMENT IS PROPRIETARY TO Y-S ELECTRONIC, ANY REPRODUCTION IN PART OR WHOLE WITHOUT PRIOR WRITTEN APPROVAL OR AUTHORIZATION OF Y-S ELECTRONIC IS STRICTLY PROHIBITED.

REV.	DESCRIPTION	ECN NO.	DWN.	CHK.	APVD.	DATE

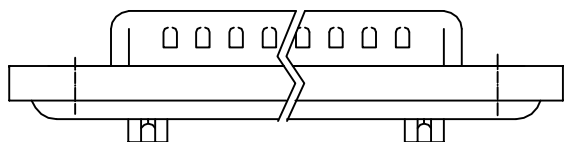
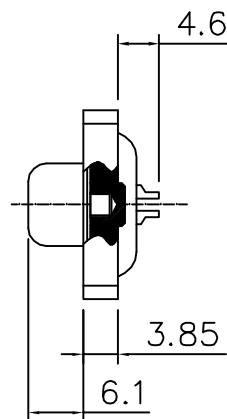
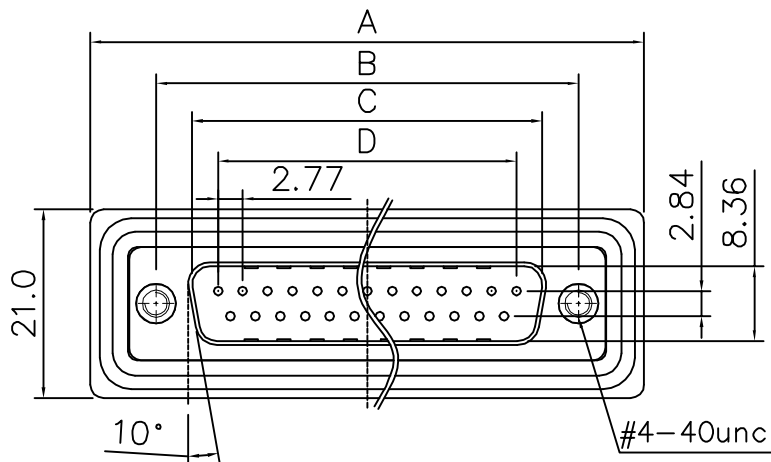

**Product Specification**

Insulator : Glass-Filled Thermoplastic PBT  
BLACK,UL94V-0

Contact : Brass

Shell : SPCC, Nickel Plated

Clinch Nut : Brass, Nickel Plated

Operating Temperature:-55 °C to +105°C

**Electrical**

Contact Resistance :

20 milliohms Max at 1 AMP DC.

Insulation Resistance :

1000 megohms at 500 VDC

Dielectric Withstanding Voltage :

1000 V RMS at 60Hz for 1 minute

Current Rating : 5 AMP

Volatge Rating : 250 V RMS at 60Hz

**DIMENSION TABLE**

POSITIONS	A±0.15	B±0.15	C±0.15	D±0.15
9	39.40	24.99	16.92	11.08
15	48.70	33.30	25.25	19.39
25	61.65	47.04	38.96	33.24
37	78.00	63.50	55.42	49.86

DIMENSIONS: <input type="checkbox"/> mm [INCH] <input type="checkbox"/> INCH [mm] <input checked="" type="checkbox"/> mm ONLY	CAD GENERATED DRAWING, DO NOT MANUALLY UPDATE DRAWN BY AND DATE JACK CHEN 2010-06-08	 <b>Y-S ELECTRONIC CO., LTD.</b> No. 101, Sec. 1, Long-An Street, Lu-Chu, Taoyuan, Taiwan, R.O.C. TEL: +886-3-3609819 FAX: +886-3-3609817
	UNLESS OTHERWISE SPECIFIED, GENERAL TOLERANCE: DECIMALS      ANGLES X. ±0.38 [0.015]    X° ±3° .X ±0.25 [0.010]    .X° ±1.0° .XX ±0.13 [0.005]	
MATERIAL:  FINISH:	SCALE: 1 : 1      SIZE: A3	DRAWING NO. 231-XX1X111      REV B
FILE NO.:		SHEET 1 OF 1

DO NOT SCALE DRAWING

THE INFORMATION CONTAINED IN THIS DOCUMENT IS PROPRIETARY TO Y-S ELECTRONIC, ANY REPRODUCTION IN PART OR WHOLE WITHOUT PRIOR WRITTEN APPROVAL OR AUTHORIZATION OF Y-S ELECTRONIC IS STRICTLY PROHIBITED.

REV.	DESCRIPTION	ECN NO.	DWN.	CHK.	APVD.	DATE

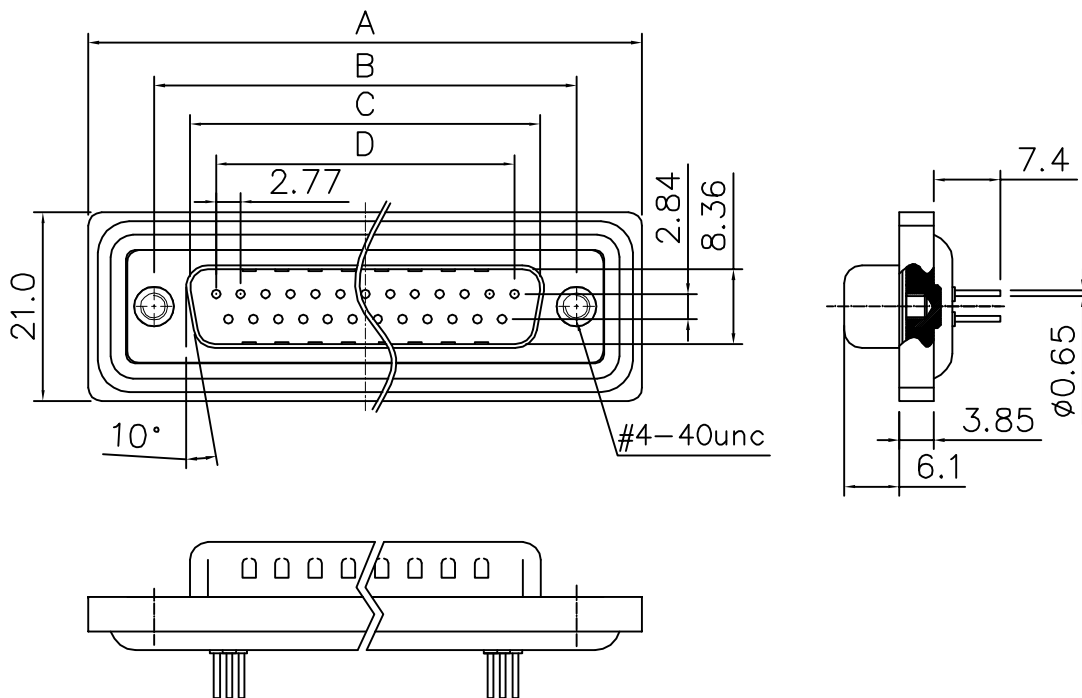

**Product Specification**  
 Insulator : Glass-Filled Thermoplastic PBT  
 BLACK,UL94V-0  
 Contact : Brass  
 Shell : SPCC, Nickel Plated  
 Clinch Nut : Brass, Nickel Plated  
 Operating Temperature:-55 °C to +105 °C

**Electrical**  
 Contact Resistance :  
 20 milliohms Max at 1 AMP DC.  
 Insulation Resistance :  
 1000 megohms at 500 VDC  
 Dielectric Withstanding Voltage :  
 1000 V RMS at 60Hz for 1 minute  
 Current Rating : 5 AMP  
 Volatge Rating : 250 V RMS at 60Hz

DIMENSION TABLE

POSITIONS	A±0.15	B±0.15	C±0.15	D±0.15
9	39.40	24.99	16.92	11.08
15	48.70	33.30	25.25	19.39
25	61.65	47.04	38.96	33.24
37	78.00	63.50	55.42	49.86

DIMENSIONS: <input type="checkbox"/> mm [INCH] <input type="checkbox"/> INCH [mm] <input checked="" type="checkbox"/> mm ONLY	CAD GENERATED DRAWING, DO NOT MANUALLY UPDATE DRAWN BY AND DATE JACK CHEN 2010-06-08	 <b>Y-S ELECTRONIC CO., LTD.</b> No. 101, Sec. 1, Long-An Street, Lu-Chu, Taoyuan, Taiwan, R.O.C. TEL: +886-3-3609819 FAX: +886-3-3609817	
			UNLESS OTHERWISE SPECIFIED, GENERAL TOLERANCE: DECIMALS      ANGLES X. ±0.38 [0.015]    X° ±3° .X ±0.25 [0.010]    .X° ±1.0° .XX ±0.13 [0.005]
MATERIAL: FINISH:	SCALE: 1 : 1      SIZE: A3	DRAWING NO. 231-XX1X211	REV B
FILE NO.:		SHEET 1 OF 1	

DO NOT SCALE DRAWING

THE INFORMATION CONTAINED IN THIS DOCUMENT IS PROPRIETARY TO Y-S ELECTRONIC, ANY REPRODUCTION IN PART OR WHOLE WITHOUT PRIOR WRITTEN APPROVAL OR AUTHORIZATION OF Y-S ELECTRONIC IS STRICTLY PROHIBITED.

REV.	DESCRIPTION	ECN NO.	DWN.	CHK.	APVD.	DATE

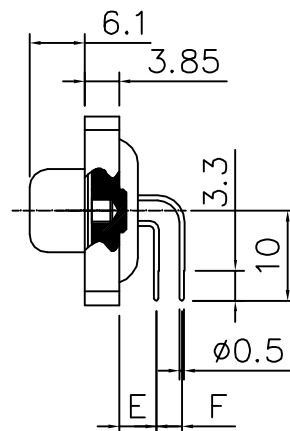
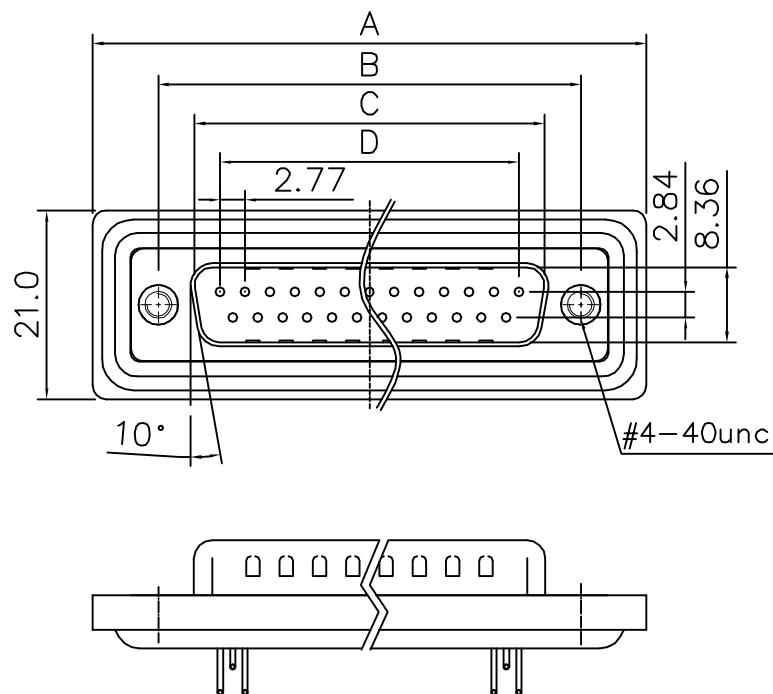

Row to Row	
E±0.15	F±0.15
4.15	2.84
6.35	2.54

**Product Specification**

Insulator : Glass-Filled Thermoplastic PBT  
BLACK,UL94V-0

Contact : Brass

Shell : SPCC, Nickel Plated

Clinch Nut : Brass, Nickel Plated

Operating Temperature:-55 °C to +105 °C

**Electrical**

Contact Resistance :  
20 milliohms Max at 1 AMP DC.

Insulation Resistance :  
1000 megohms at 500 VDC

Dielectric Withstanding Voltage :  
1000 V RMS at 60Hz for 1 minute

Current Rating : 5 AMP

Volatge Rating : 250 V RMS at 60Hz

DIMENSION TABLE

POSITIONS	A±0.15	B±0.15	C±0.15	D±0.15
9	39.40	24.99	16.92	11.08
15	48.70	33.30	25.25	19.39
25	61.65	47.04	38.96	33.24
37	78.00	63.50	55.42	49.86

DIMENSIONS: <input type="checkbox"/> MM [INCH] <input type="checkbox"/> INCH [mm] <input checked="" type="checkbox"/> MM ONLY	CAD GENERATED DRAWING, DO NOT MANUALLY UPDATE DRAWN BY AND DATE JACK CHEN 2010-06-08
UNLESS OTHERWISE SPECIFIED, GENERAL TOLERANCE: DECIMALS X. ±0.38 [0.015] .X ±0.25 [0.010] .XX ±0.13 [0.005]	CHECKED BY AND DATE JACK CHEN 2010-06-08 APPROVED BY AND DATE FRANKY CHEN 2010-06-08
MATERIAL:	THIRD ANGLE PROJECTION
FINISH:	SCALE: 1:1 SIZE: A3

**Y-S ELECTRONIC CO., LTD.**  
No. 101, Sec. 1, Long-An Street,  
Lu-Chu, Taoyuan, Taiwan, R.O.C.  
TEL: +886-3-3609819 FAX: +886-3-3609817

TITLE D-Sub Type Waterproof	
DRAWING NO. 231-XX1XX11	REV B
FILE NO.:	SHEET 1 OF 1

DO NOT SCALE DRAWING

THE INFORMATION CONTAINED IN THIS DOCUMENT IS PROPRIETARY TO Y-S ELECTRONIC, ANY REPRODUCTION IN PART OR WHOLE WITHOUT PRIOR WRITTEN APPROVAL OR AUTHORIZATION OF Y-S ELECTRONIC IS STRICTLY PROHIBITED.

REV.	DESCRIPTION	ECN NO.	DWN.	CHK.	APVD.	DATE

## Ordering Information

231 -  $\frac{XX}{a}$   $\frac{X}{b}$   $\frac{X}{c}$   $\frac{X}{d}$   $\frac{X}{e}$   $\frac{X}{f}$   $\frac{X}{g}$   $\frac{X}{h}$

### a. No. of Pins

- 09: 09 Positions
- 15: 15 Positions
- 25: 25 Positions
- 37: 37 Positions

### b. Contact Type:

- 1: Male
- 2: Female

### c. Contact Plating:

- 0: Gold Flash Overall
- 1: 15u" Gold
- 2: 30u" Gold

### d. Type

- 1: Solder Type
- 2: Dip Type
- 3: Right Angle Type (4.15mm)
- 4: Right Angle Type (6.35mm)



### e. Screw Type

- 1: #4-40 UNC(Standard)
- 2: M3
- 3: M2.6
- 4: #4-40 Threaded Hole with #4-40 UNC  
(4.8\*11.8mm) Screwlock Bulk-Packed
- 5: #4-40 Threaded Hole with #4-40 UNC  
(6.0\*11.0mm) Screwlock Installed

### F: Row to Row (Dimension E):

- 1: 2.84mm
- 2: 2.54mm (Only for Right Angle Type)

DO NOT SCALE DRAWING

DIMENSIONS: <input type="checkbox"/> MM [INCH] <input type="checkbox"/> INCH [mm] <input checked="" type="checkbox"/> MM ONLY		CAD GENERATED DRAWING, DO NOT MANUALLY UPDATE DRAWN BY AND DATE JACK CHEN 2010-06-08		 <b>Y-S ELECTRONIC CO., LTD.</b> No. 101, Sec. 1, Long-An Street, Lu-Chu, Taoyuan, Taiwan, R.O.C. TEL: +886-3-3609819 FAX: +886-3-3609817	
UNLESS OTHERWISE SPECIFIED, GENERAL TOLERANCE: DECIMALS      ANGLES X. ±0.38 [0.015]   X° ±3° .X ±0.25 [0.010]   .X° ±1.0° .XX ±0.13 [0.005]		CHECKED BY AND DATE JACK CHEN 2010-06-08 APPROVED BY AND DATE FRANKY CHEN 2010-06-08 THIRD ANGLE PROJECTION		TITLE <p style="text-align: center;">D-Sub Type Waterproof</p>	
MATERIAL:				DRAWING NO. <p style="text-align: center;">231-XXXXXX</p>	
FINISH:		SCALE: 1 : 1		SIZE: A3	
FILE NO.:				SHEET 1 OF 1	