

THE INFORMATION CONTAINED IN THIS DOCUMENT IS PROPRIETARY TO Y-S ELECTRONIC. ANY REPRODUCTION IN PART OR WHOLE WITHOUT PRIOR WRITTEN APPROVAL OR AUTHORIZATION OF Y-S ELECTRONIC IS STRICTLY PROHIBITED.

RoHS COMPLIANT

REVISIONS				
REV	ECN NO.	DESCRIPTION	APPROVED BY	DATE

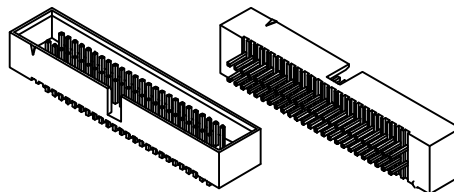
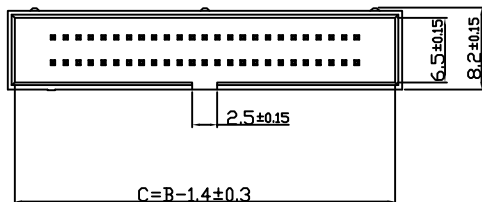

Product Specification

Material

Insulator :Glass-Filled High Thermoplastic
UL94V-0 rates,
Contact :Brass

Electrical

Contact Resistance :30 milliohms
Max at 1 AMP DC.
Insulation Resistance :1000
magohms at 500 VDC
Dielectric Withstanding Voltage :
500 VAC/rms 60Hz for 1 minute
Current Rating :1 AMP
Volatge Rating :250 VAC/rms 60Hz

Dimensions

Positions	A	B
8	3.81	13.10
10	5.08	14.37
20	11.43	20.72
26	15.24	24.53
30	17.78	27.07
34	20.32	29.61
40	24.13	33.42
44	26.67	35.96
50	30.48	39.77
60	36.83	46.12
68	41.91	51.20
80	49.53	58.82
100	62.23	71.52

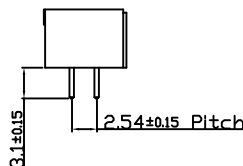
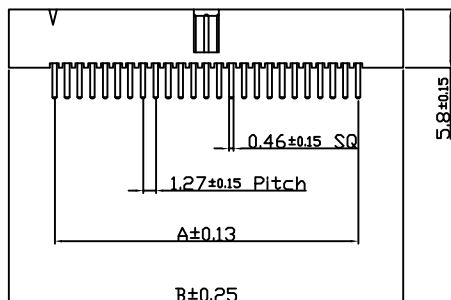

Ordering Information

118a - $\frac{XX}{a} \frac{X}{b} \frac{X}{c} \frac{X}{d}$

- a. No. Of Pins
- b. Contact Plating
 - 0: Gold Flash selective gold
 - 1: 5u' selective gold on contact
 - 2: 10u' selective gold on contact
 - 3: 15u' selective gold on contact
 - 4: 30u' selective gold on contact
 - 5: 50u' selective gold on contact
 - 6: Gold flash full gold(standard)
- c. Terminal Type
 - 0: 180°
 - 1: 90°
 - S: SMT TYPE
- d. Insulator Color
 - 0: Black(Nylon 6T)

DO NOT SCALE DRAWING

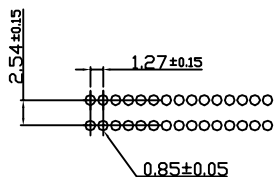

BOX HEADER 1.27*2.54mm STRAIGHT TYPE
Recommended P.C.B Layout

DIMENSIONS: <input type="checkbox"/> MM [INCH] <input type="checkbox"/> INCH [mm] <input checked="" type="checkbox"/> MM ONLY		CAD GENERATED DRAWING, DO NOT MANUALLY UPDATE	
UNLESS OTHERWISE SPECIFIED, GENERAL TOLERANCE: DECIMALS ANGLES X: ±0.38 [0.015] X° ±3° .X ±0.25 [0.010] .X° ±1.0° .XX ±0.13 [0.005]		CHECKED BY AND DATE JUSTIN XING 03-21-08	
MATERIAL:		APPROVED BY AND DATE MICHAEL HUANG 03-21-08	
FINISH:		THIRD ANGLE PROJECTION	
SCALE: 2 : 1		SIZE: A3	



Y-S ELECTRONIC CO., LTD.
 No. 101, Sec. 1, Long-An Street,
 Lu-Chu, Taoyuan, Taiwan, R.O.C.
 TEL: +886-3-3609819 FAX: +886-3-3609817

TITLE 118a SERIES BOX HEADER 1.27*2.54MM (0.05"*0.100") <2 Rows>	
DRAWING NO. 118a-XXXXX	REV A
FILE NO.	SHEET 1 OF 3

THE INFORMATION CONTAINED IN THIS DOCUMENT IS PROPRIETARY TO Y-S ELECTRONIC. ANY REPRODUCTION IN PART OR WHOLE WITHOUT PRIOR WRITTEN APPROVAL OR AUTHORIZATION OF Y-S ELECTRONIC IS STRICTLY PROHIBITED.

RoHS COMPLIANT

REVISIONS				
REV	ECN NO.	DESCRIPTION	APPROVED BY	DATE

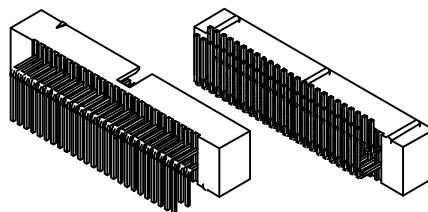
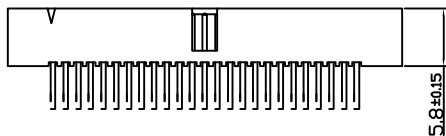

Product Specification

Material

Insulator :Glass-Filled High Thermoplastic
UL94V-0 rates,
Contact :Brass

Electrical

Contact Resistance :30 milliohms
Max at 1 AMP DC.
Insulation Resistance :1000
mohms at 500 VDC
Dielectric Withstanding Voltage :
500 VAC/rms 60Hz for 1 minute
Current Rating :1 AMP
Volatge Rating :250 VAC/rms 60Hz

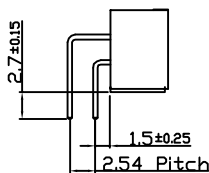
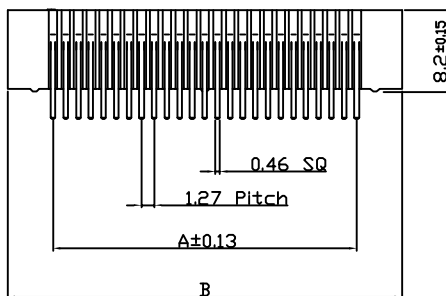

Dimensions

Positions	A	B
8	3.81	13.10
10	5.08	14.37
20	11.43	20.72
26	15.24	24.53
30	17.78	27.07
34	20.32	29.61
40	24.13	33.42
44	26.67	35.96
50	30.48	39.77
60	36.83	46.12
68	41.91	51.20
80	49.53	58.82
100	62.23	71.52

Ordering Information

118a - $\frac{XX}{a} \frac{X}{b} \frac{X}{c} \frac{X}{d}$

- a. No. Of Pins
- b. Contact Plating
 - 0: Gold Flash selective gold
 - 1: 5u' selective gold on contact
 - 2: 10u' selective gold on contact
 - 3: 15u' selective gold on contact
 - 4: 30u' selective gold on contact
 - 5: 50u' selective gold on contact
 - 6: Gold flash full gold(standard)
- c. Terminal Type
 - 0: 180°
 - 1: 90°
 - S: SMT TYPE
- d. Insulator Color
 - 0: Black(Nylon 6T)

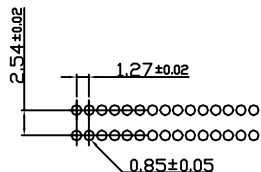

BOX HEADER 1.27*2.54mm R/A TYPE
Recommended P.C.B Layout

DO NOT SCALE DRAWING

DIMENSIONS: <input type="checkbox"/> MM [INCH] <input type="checkbox"/> INCH [mm] <input checked="" type="checkbox"/> MM ONLY		CAD GENERATED DRAWING, DO NOT MANUALLY UPDATE	
UNLESS OTHERWISE SPECIFIED, GENERAL TOLERANCE: DECIMALS ANGLES X: ±0.38 [0.015] X° ±3° .X ±0.25 [0.010] .X° ±1.0° .XX ±0.13 [0.005]		CHECKED BY AND DATE JUSTIN XING 03-21-08	
MATERIAL:		APPROVED BY AND DATE MICHAEL HUANG 03-21-08	
FINISH:		THIRD ANGLE PROJECTION	
SCALE: 2 : 1		SIZE: A3	

DRAWN BY AND DATE JUSTIN XING 03-21-08		TITLE 118a SERIES BOX HEADER 1.27*2.54MM (0.05"*0.100") <2 Rows>	
DRAWING NO. 118a-XXXXX		REV A	
FILE NO.		SHEET 2 OF 3	



Y-S ELECTRONIC CO., LTD.
No. 101, Sec. 1, Long-An Street,
Lu-Chu, Taoyuan, Taiwan, R.O.C.
TEL: +886-3-3609819 FAX: +886-3-3609817

THE INFORMATION CONTAINED IN THIS DOCUMENT IS PROPRIETARY TO Y-S ELECTRONIC. ANY REPRODUCTION IN PART OR WHOLE WITHOUT PRIOR WRITTEN APPROVAL OR AUTHORIZATION OF Y-S ELECTRONIC IS STRICTLY PROHIBITED.

RoHS COMPLIANT

REVISIONS				
REV	ECN NO.	DESCRIPTION	APPROVED BY	DATE

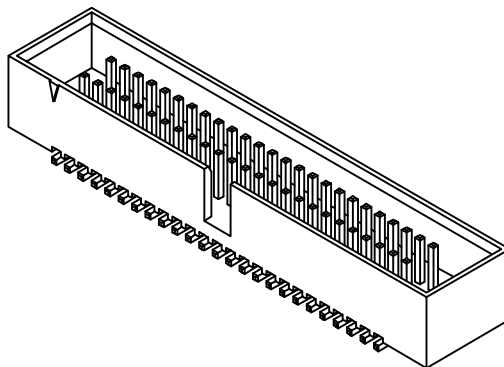
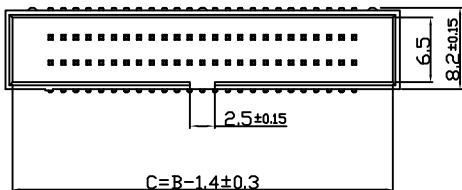

Product Specification

Material

Insulator :Glass-Filled High Thermoplastic
UL94V-0 rates,
Contact :Brass

Electrical

Contact Resistance :30 milliohms
Max at 1 AMP DC.
Insulation Resistance :1000
magohms at 500 VDC
Dielectric Withstanding Voltage :
500 VAC/rms 60Hz for 1 minute
Current Rating :1 AMP
Volatge Rating :250 VAC/rms 60Hz

Dimensions

Positions	A	B
8	3.81	13.10
10	5.08	14.37
20	11.43	20.72
26	15.24	24.53
30	17.78	27.07
34	20.32	29.61
40	24.13	33.42
44	26.67	35.96
50	30.48	39.77
60	36.83	46.12
68	41.91	51.20
80	49.53	58.82
100	62.23	71.52

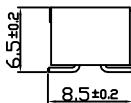
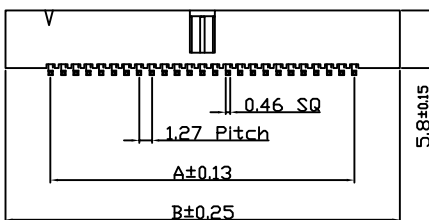

Ordering Information

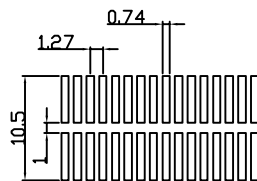

118a - $\frac{XX}{a} \frac{X}{b} \frac{X}{c} \frac{X}{d}$

- a. No. Of Pins
- b. Contact Plating
 - 0: Gold Flash selective gold
 - 1: 5u' selective gold on contact
 - 2: 10u' selective gold on contact
 - 3: 15u' selective gold on contact
 - 4: 30u' selective gold on contact
 - 5: 50u' selective gold on contact
 - 6: Gold flash full gold(standard)
- c. Terminal Type
 - 0: 180°
 - 1: 90°
 - S: SMT TYPE
- d. Insulator Color
 - 0: Black(Nylon 6T)



BOX HEADER 1.27*2.54mm SMT TYPE
Recommended P.C.B Layout

DO NOT SCALE DRAWING

DIMENSIONS: <input type="checkbox"/> MM [INCH] <input type="checkbox"/> INCH [mm] <input checked="" type="checkbox"/> MM ONLY	CAD GENERATED DRAWING, DO NOT MANUALLY UPDATE	 Y-S ELECTRONIC CO., LTD. No. 101, Sec. 1, Long-An Street, Lu-Chu, Taoyuan, Taiwan, R.O.C. TEL: +886-3-3609819 FAX: +886-3-3609817	
	UNLESS OTHERWISE SPECIFIED, GENERAL TOLERANCE: DECIMALS ANGLES X: ±0.38 [0.015] X° ±3° .X ±0.25 [0.010] .X° ±1.0° .XX ±0.13 [0.005]		DRAWN BY AND DATE JUSTIN XING 03-21-08 CHECKED BY AND DATE JUSTIN XING 03-21-08 APPROVED BY AND DATE MICHAEL HUANG 03-21-08 THIRD ANGLE PROJECTION
MATERIAL		DRAWING NO.	REV
FINISH		SCALE: 2 : 1	SIZE: A3
		FILE NO.	SHEET 3 OF 3