

THE INFORMATION CONTAINED IN THIS DOCUMENT IS PROPRIETARY TO Y-S ELECTRONIC. ANY REPRODUCTION IN PART OR WHOLE WITHOUT PRIOR WRITTEN APPROVAL OR AUTHORIZATION OF Y-S ELECTRONIC IS STRICTLY PROHIBITED.

RoHS COMPLIANT

REVISIONS

REV	ECN NO.	DESCRIPTION	APPROVED BY	DATE

NOTES

1.MATERIAL

- 1.1 Insulator: P.B.T. +15% G.F. UL-94V-0
- 1.2 Contact: Phosphor Bronze

2.SPECIFICATION

- 2.1 Current Rating: 3Amp
- 2.2 Dielectric Withstanding: AC 1000V min.Per minute
- 2.3 Insulation Resistance: 1000M ohms At DC 500V
- 2.4 Contact Resistance: 25 M ohms Max
- 2.5 Contact Insertion Force: 1kg max
- 2.6 Contact Separation force: 70g min
- 2.7 Operating Temperature: -55°C To +85°C

Ordering Information

117 - $\frac{x}{a} \frac{x}{b} \frac{x}{c}$

- a. Type
 - 1: AC(close) Type
 - 2: BK(open) Type
- b. Contact Plating
 - 1: 5u" Gold Flash full gold
 - 2: 10u" Gold Flash Full gold
 - 3: 15u" Gold Flash Full gold
 - 4: 30u" Gold flash full gold
 - 5: 50u" Gold Flash full gold
 - 6: Gold Flash full gold(standard)
 - 7: Full tin
- c. Insulator Color
 - 0: Black(standard)
 - 1: White
 - 2: Red
 - 3: Yellow
 - 4: Green
 - 5: Blue

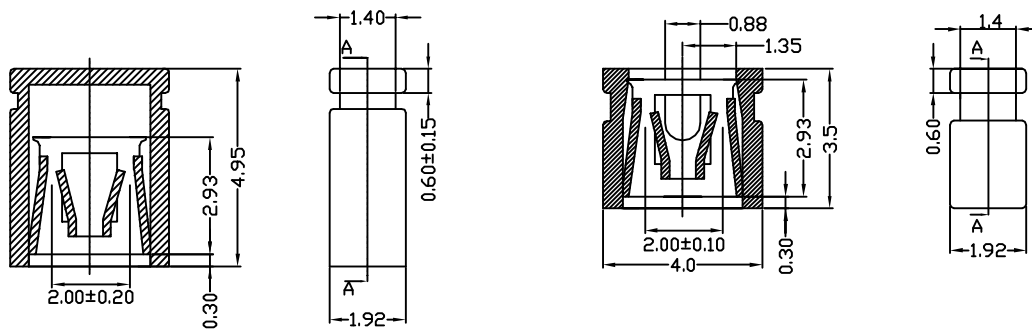

SEC A-A

SEC A-A

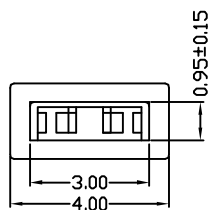

A TYPE

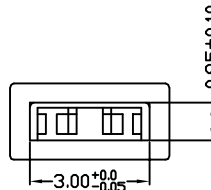

B TYPE

DO NOT SCALE DRAWING

DIMENSIONS: <input type="checkbox"/> MM [INCH] <input type="checkbox"/> INCH [mm] <input checked="" type="checkbox"/> MM ONLY	CAD GENERATED DRAWING, DO NOT MANUALLY UPDATE	Y-S ELECTRONIC CO., LTD. No. 101, Sec. 1, Long-An Street, Lu-Chu, Taoyuan, Taiwan, R.O.C. TEL: +886-3-3609819 FAX: +886-3-3609817	
	UNLESS OTHERWISE SPECIFIED, GENERAL TOLERANCE: DECIMALS ANGLES X: ±0.38 [0.015] X°: ±3° .X: ±0.25 [0.010] .X°: ±1.0° .XX: ±0.13 [0.005]		DRAWN BY AND DATE JAY ZHANG 03-22-08
MATERIAL: _____ FINISH: _____	CHECKED BY AND DATE JUSTIN XING 03-22-08 APPROVED BY AND DATE MICHAEL HUANG 03-22-08 THIRD ANGLE PROJECTION 	DRAWING NO. 117-XXX	REV A
SCALE: 8 : 1	SIZE: A3	FILE NO.: _____	SHEET 1 OF 1